

MHS

Heavy-Duty Secondary Belt Cleaner

Superior Cleaning on the Toughest Belts

The MHS Heavy-Duty Secondary Belt Cleaner was designed to deliver and maintain superior cleaning efficiency, even on the most demanding, abusive beltlines. The MHS is the new answer to tough belt cleaning problems. It delivers high-efficiency cleaning, long-lasting performance—and with low maintenance.

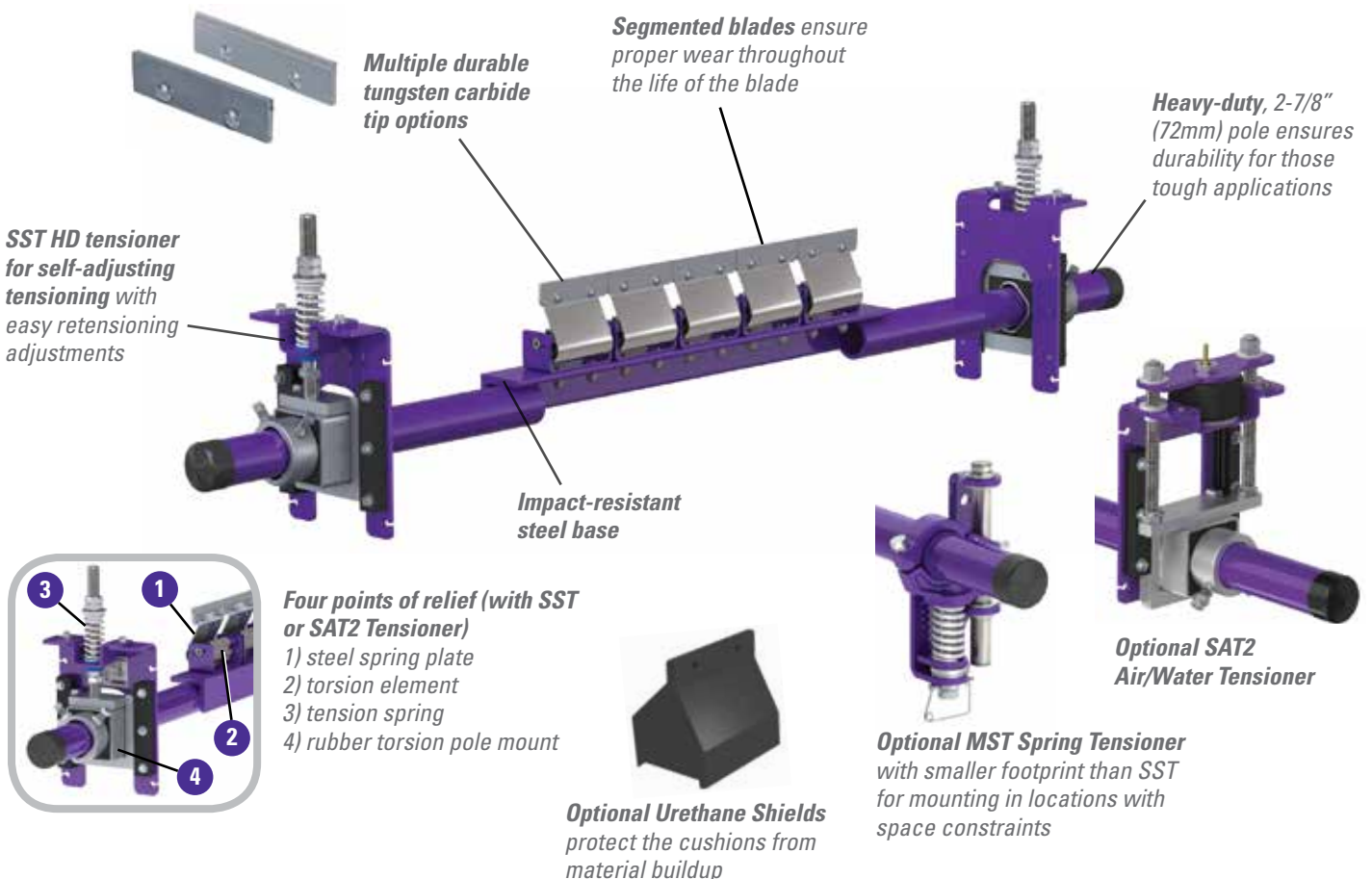

Features and Benefits

- **Cleaning efficiency of metal blades.** The thin, hard edges of the metal blades deliver high cleaning efficiency and long wear life.
- **Works with Flexco mechanical splices.** The C-Tip tungsten carbide blades are impact-resistant, and the spring cushion allows them to move away from a passing splice without damage and with minimal cleaning disruption. V-Tips can be used only on vulcanized belts.
- **A complete cleaning system.** When the MHS is teamed with the MMP precleaner the system provides maximum cleaning power for tough applications.
- **Made for mining conveyors.** Made from heavy-duty, corrosion-resistant steel, the MHS is available in sizes for belt widths from 450 to 2400mm. Additional sizes are available upon request.
- **Safe to service.** All service can be performed from a safe position at the side of the conveyor.
- **Also available in stainless steel.**

MHS Heavy-Duty Secondary Belt Cleaner

Specifications and Guidelines

Maximum Belt Speed

6 M/sec

5 M/sec with MST Tensioner

Temperature Rating

-35° C to 82° C

Usable Blade Wear Length

9mm

Blade Material

Impact resistant, long-lasting tungsten carbide (C-Tip for mechanical fasteners, V-Tips for vulcanized belts)

Available for Belt Widths

450 to 2400mm with SST or SAT2 Tensioner

450 to 1800mm with MST Tensioner

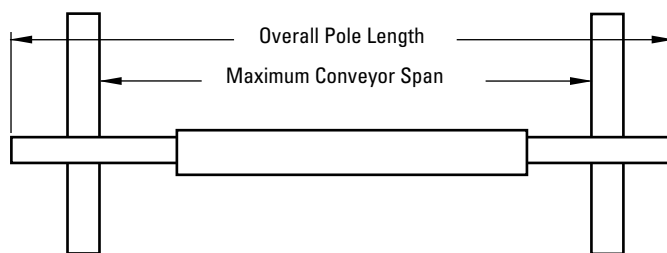

Pole Length Cleaner size +1350mm

Maximum Conveyor Span Cleaner size + 1100mm

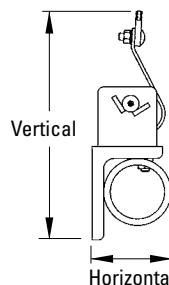

Horizontal Clearance Required
100mm

Vertical Clearance Required
245mm

Ordering Information

MHS HD Secondary with C-Tips

Belt Width	Ordering	Item	
mm	in.	Number	Code
600	24	MHS-24	75910
750	30	MHS-30	75911
900	36	MHS-36	75912
1050	42	MHS-42	75913
1200	48	MHS-48	75914
1350	54	MHS-54	75915
1500	60	MHS-60	75916
1800	72	MHS-72	75917
2100	84	MHS-84	76803
2400	96	MHS-96	79043

MHS HD Secondary with V-Tips*

Belt Width	Ordering	Item	
mm	in.	Number	Code
450	18	MHS-18V	76169
600	24	MHS-24V	76170
750	30	MHS-30V	76171
900	36	MHS-36V	76172
1050	42	MHS-42V	76173
1200	48	MHS-48V	76174
1350	54	MHS-54V	76175
1500	60	MHS-60V	76176
1800	72	MHS-72V	76177
2100	84	MHS-84V	76804
2400	96	MHS-96V	79044

*V-Tips can be used ONLY on vulcanized belts

MHS with MST and V-Tips*

Belt Width	Ordering	Item	
mm	in.	Number	Code
450	18	MHS-18V-MST	79442
600	24	MHS-24V-MST	79443
750	30	MHS-30V-MST	79444
900	36	MHS-36V-MST	79445
1050	42	MHS-42V-MST	79446
1200	48	MHS-48V-MST	79447
1350	54	MHS-54V-MST	79448
1500	60	MHS-60V-MST	79449
1800	72	MHS-72V-MST	79450

*V-Tips can be used ONLY on vulcanized belts

MHS with PAT*

Belt Width	Ordering	Item	
mm	in.	Number	Code
600	24	MHS-24P	78736
750	30	MHS-30P	78737
900	36	MHS-36P	78738
1050	42	MHS-42P	78739
1200	48	MHS-48P	78740
1350	54	MHS-54P	78741
1500	60	MHS-60P**	78742
1800	72	MHS-72P**	78743
2100	84	MHS-84P**	78744
2400	96	MHS-96P**	79047

*Includes Control Box
**60", 72" and 96" models have a 3-piece pole.

MHS Reversing with C-Tips

Belt Width	Ordering	Item	
mm	in.	Number	Code
600	24	MHS-24R	76613
750	30	MHS-30R	76614
900	36	MHS-36R	76615
1050	42	MHS-42R	76616
1200	48	MHS-48R	76617
1350	54	MHS-54R	76618
1500	60	MHS-60R	76619
1800	72	MHS-72R	76620
2100	84	MHS-84R	76621
2400	96	MHS-96R	79045

MHS Reversing with V-Tips*

Belt Width	Ordering	Item	
mm	in.	Number	Code
450	18	MHS-18RV	76646
600	24	MHS-24RV	76647
750	30	MHS-30RV	76648
900	36	MHS-36RV	76649
1050	42	MHS-42RV	76650
1200	48	MHS-48RV	76651
1350	54	MHS-54RV	76652
1500	60	MHS-60RV	76653
1800	72	MHS-72RV	76654
2100	84	MHS-84RV	76805
2400	96	MHS-96RV	79046

*V-Tips can be used ONLY on vulcanized belts

Replacement Tips

Ordering	Item
Number	Code
ICT6	74535
RSA150	73628

Urethane Shields

Ordering	Item
Number	Code
UPFCC	79320

Tips Required Per Cleaner Size

mm	450	600	750	900	1050	1200	1350	1500	1800	2100	2400
in.	18	24	30	36	42	48	54	60	72	84	96
C-Tips or V-Tips Required	3	4	5	6	7	8	9	10	12	14	16

Authorized Distributor:

上海市松江区新润路388号17幢 (邮编: 201612)

电话: 0086-21-33528388 • 传真: 0086-21-33528058 • 电子邮件: chinasales@flexco.com

客服热线: 400 820 6896

请访问 www.flexco.com 网站, 了解 Flexco 其他分公司和产品。

©2014 Flexible Steel Lacing Company. 12/14. For reorder: Xx1650

